

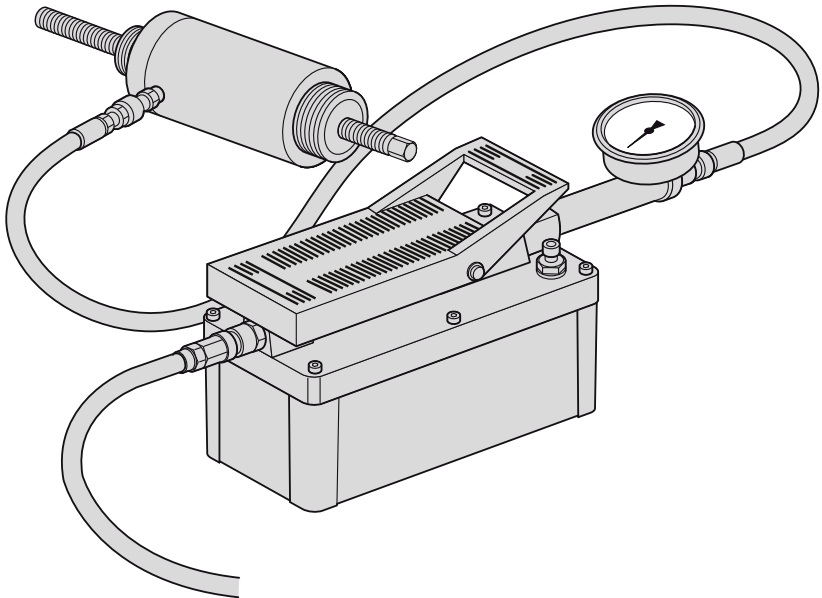

Hydraulic
press/puller
tools

For axle repairs and
bushing replacement

K 22500
K 22501



INRODUCTION

This is a modular system built around a hydraulic cylinder delivering a working pressure of 17 ton, to remove and install drive shaft, wheel hubs, wheel bearings, silent blocks and suspension ball joints in a safe and efficient way. Some accessory tools are specially made for this hydraulic system while other are sold as tool sets to be manually operated as well as hydraulically. This manual gives a general introduction to the tool system and how to handle it, while more detailed information such as spare part lists for a specific tool can be found on our web and in the packaging of a new tool.

SAFETY AND PRECAUTION

- Read this manual completely before starting to assembly and use the tools.
- Always keep in mind that this hydraulic cylinder produces up to 17 ton of pressure. This puts very high demands on securing that all tools attached to the cylinder and the workpiece are aligned and can not slip or in any other way cause danger.
- Always follow instructions provided by the vehicle manufacturer regarding handling and safety measures.
- Use eye protection and safety gloves.
- The tool is not designed for use together with impact wrenches.
- Do not knock on any part of the tool during load.
- Keep this equipment out of reach for children.

Only authorized persons that have read and understood these instructions should operate the hydraulic tools. Kamasa Tools does not take responsibility for damage or injuries caused by unsafe use, lack of maintenance or use together with components not designed to be used with this tool.

OPERATION INSTRUCTIONS

- It's very important not to exceed maximum inlet air pressure of 8,5 bar (120 psi).
- In order to avoid damage to adapters, fittings and manometer, these parts are not mounted to the cylinder and pump at delivery. Use sealing tape or liquid thread sealant on the parts that are screwed on the cylinder/ pump and check that there are no leaks once the system is connected to compressed air.
- Fill the oil pump with 1600 ml hydraulic oil SAE 10.
- Connect pump, hose and cylinder before connecting the compressed air and test run the system before use.
- Press the pedal backward to apply hydraulic pressure to the cylinder. Release pressure by pushing the pedal forward, RELEASE
- If the system needs priming, push the pedal forward, RELEASE mode and press the valve under the back of the pedal for 15 seconds, this operation will prime the system.
- Operations that can be performed by the hydraulic system in combination with Kamasa Tools special tools are described on the following pages.

MAINTENANCE

- Never attempt to disengage parts of the system or disassemble the pump or cylinder before disconnecting the air pressure.
- Check the system periodically for hydraulic or air leaks.
- Release air pressure when stored.

APPLICATIONS

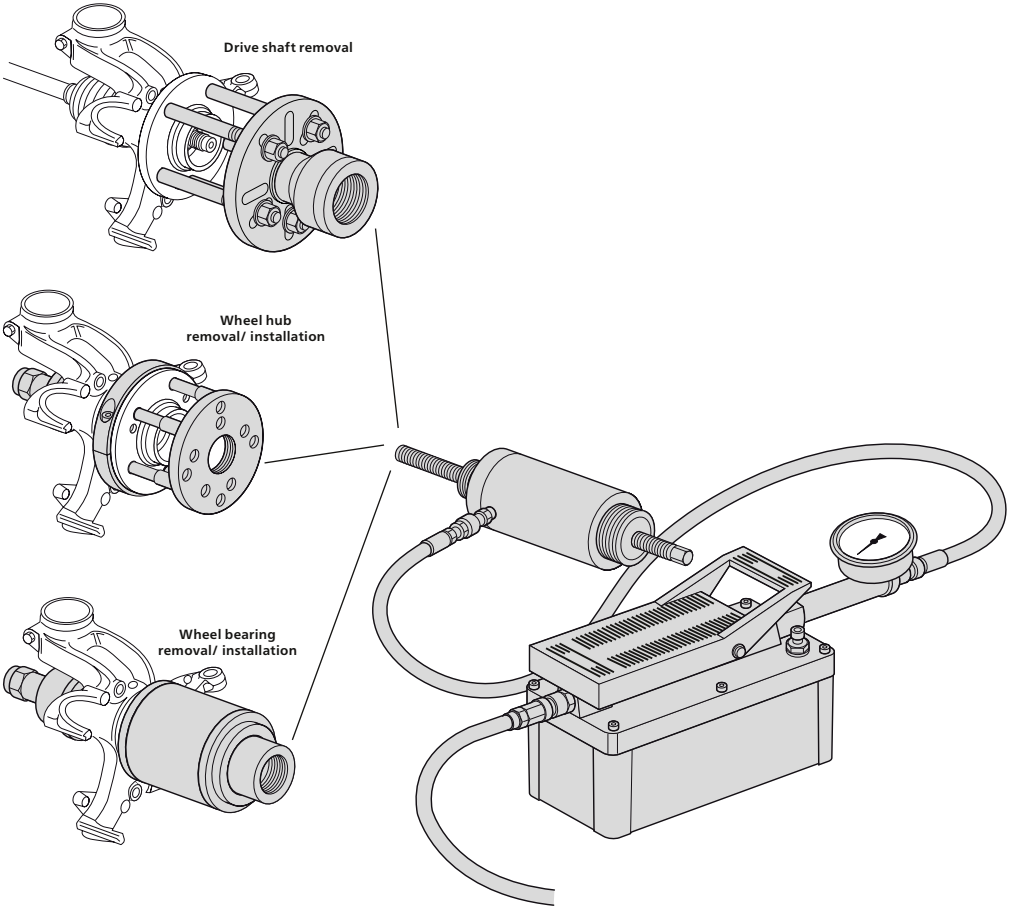

HYDRAULIC CYLINDER, 17 TON, K 22500

The tubular cylinder can be used for both pressing and pulling and can be combined with several adapters, spindles and press sleeves. It is operated in combination with the foot maneuvered hydraulic pump, K 22501.

Features

Capacity	17 tons
Stroke	45 mm
Outer thread on pulling side	M42x2
Inner thread on pressing side	2 ¼"-14 UNS
Inner thread in piston	M20x2,5 mm
Length with extracted piston	202 mm
Weight	5,1 kg

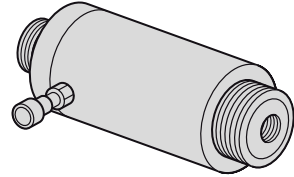

HYDRAULIC PUMP, K 22501

This pump is operated with compressed air which the pump convert into hydraulic pressure. It is operated in combination with the hydraulic cylinder, K 22500.

Features

Operating pressure	7,0–8,5 bar (100–120psi)
Air connection	¼"
Hydraulic oil	SAE 10 1600 ml
Weight	8 kg

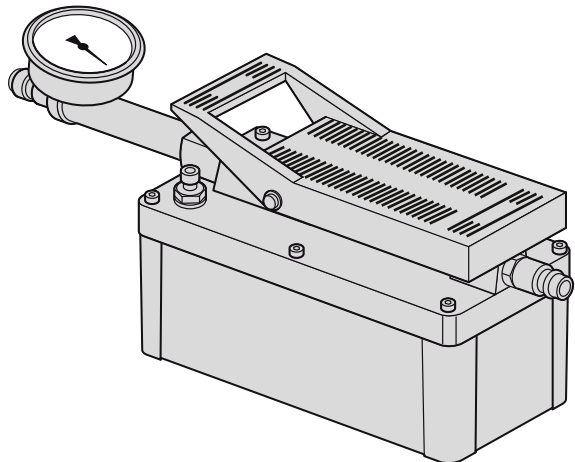

ACCESSORIES

Pull spindle, K 22510
M20×570 mm



Pressure spindle, K 22511
M20×350 mm



Pressure piece, K 22512



Adapter with threads 2 1/4-14 UNS, K 22509



Adapter 101 in press tool set, K 10321



Double headed nut, K 22505
Ø29&20 mm



Puller disc, K 22506
For 3 to 5 holes

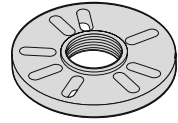

Adapter 2 1/4"-14UNS to 2 1/4"-14UNS, K 22507

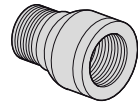

Adapter 2 1/4"-14UNS to M20, K 22515



Press plate, K 22508

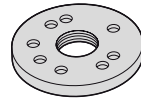

Pin set for 78–82 mm bearings, K 22513



Pin set for 62–72 mm bearings, K 22514

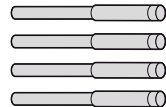

REMOVAL AND INSTALLATION OF WHEEL BEARINGS

In this application the hydraulic cylinder is used together with the press tool set K 10204. A detailed work description is included in the manual for this tool set. Here is a short version:

REMOVAL

- 1 Measure the inner and outer diameter of the bearing
- 2 Select press ring (360–385*), center ring (234–245*) and support ring (403–405*)
- 3 Assemble together with the the other parts according to the illustration.
- 4 Turn the nut (K 22505) in by hand and secure that all parts are in place before adding pressure to the cylinder.

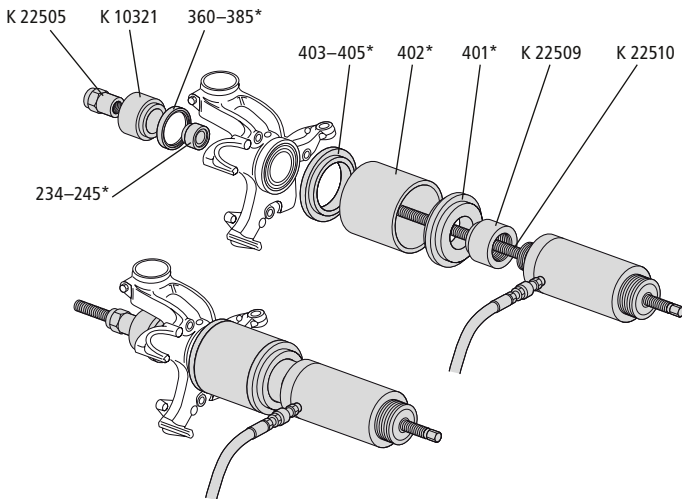

* Numbers printed on the parts in K 10204

INSTALLATION

- 1 After cleaning and checking the contact surface in the hub, a new wheel bearing can be installed.
- 2 Select press ring (360-385*) a centering ring (234-245*) and a supporting ring (360-385).
- 3 Assemble together with the other parts and the new bearing according to the illustration.
- 4 Turn the nut (K 22505) in by hand and secure that all parts are in place before adding pressure to the cylinder.

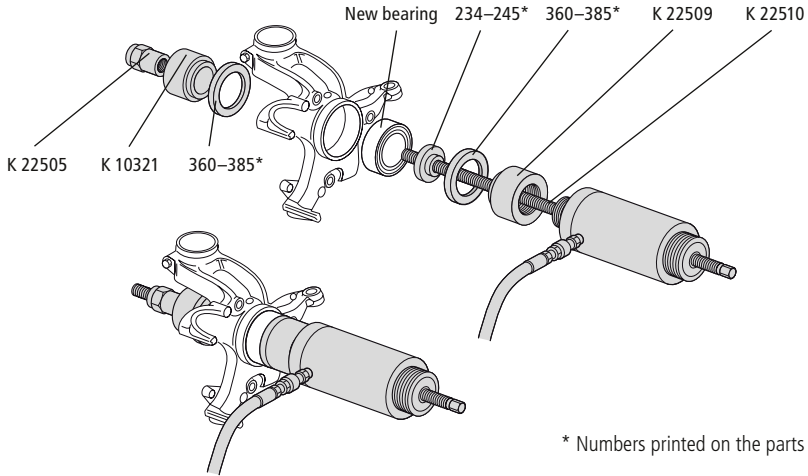

* Numbers printed on the parts in K 10204

INSTALLATION OF WHEEL HUB

- 1 Select rings (360-385*) that fits as a support on the backside of the inner bearing race and as a pressure ring on the hub.
- 2 Assemble together with the other parts according to the illustration.
- 3 Turn the nut (K 22505) in by hand and secure that all parts are in place before adding pressure to the cylinder.

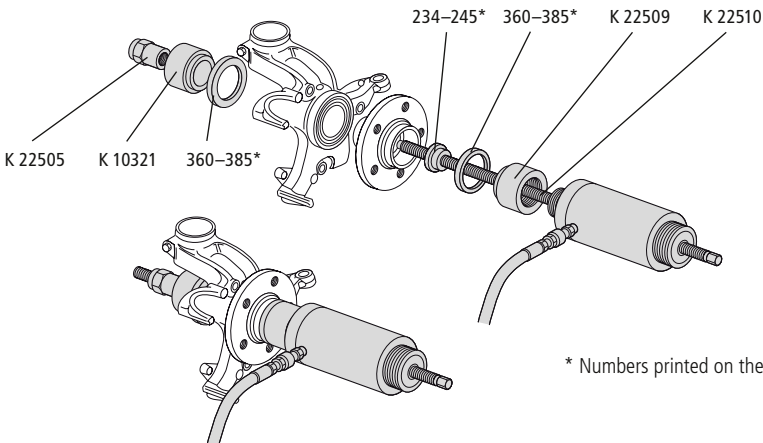

* Numbers printed on the parts in K 10204

REMOVAL AND INSTALLATION OF WHEEL HUB WITH BEARING

In this application the hydraulic cylinder is used together with the removal and installations sets, K 10348 – K 10354 and K 10594 – K 10595.

REMOVAL

- 1 Based on the bearing dimensions, select removal kit (K 10348 – K 10595).
- 2 Mount the two halves of the support ring and select the pin set (K 22513 - K 22514) that fits through the holes in the wheel hub.
- 3 Turn the pressure plate to fit the pattern of the pushrods and fit it to the cylinder.
- 4 Assembly all the components according to the illustration.
- 5 Turn the nut (K 22505) in by hand and secure that all parts are in place before adding pressure to the cylinder.

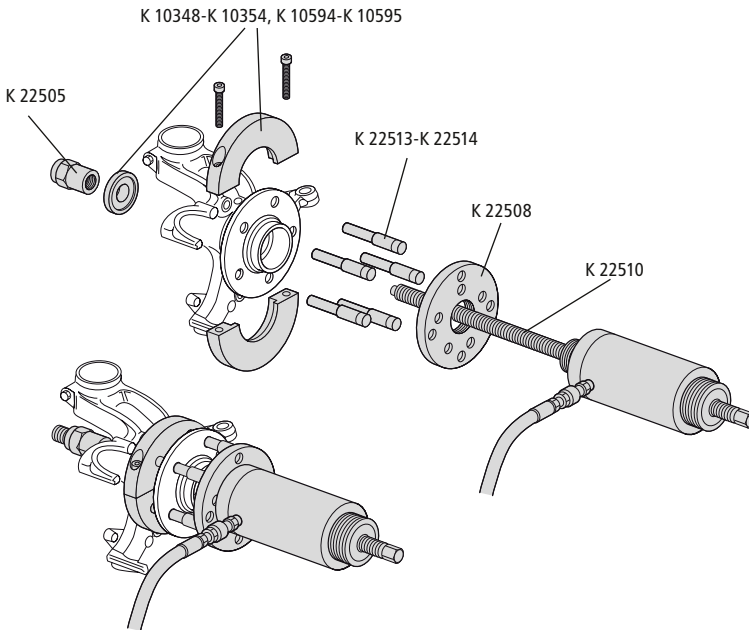

INSTALLATION

- 1 Based on the bearing dimensions, select installation kit (K 10348 – K 10595).
- 2 Mount the two halves of the pressure ring and select the pin set (K 22513- K 22514) that fits through the holes in the wheel hub.
- 3 Turn the pressure plate to fit the pattern of the pushrods and fit it to the cylinder.
- 4 Assembly all the components according to the illustration.
- 5 Turn the nut (K 22505) in by hand and secure that all parts are in place before adding pressure to the cylinder.

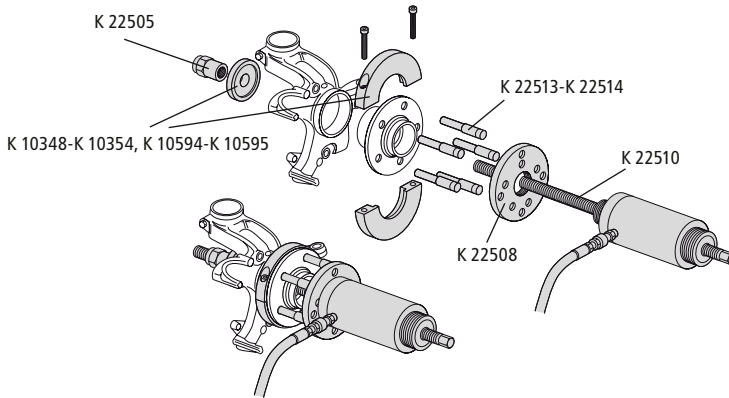

REMOVAL OF DRIVE SHAFT

- 1 Based on wheel nut dimension, select extension rods (K 10355-K 10356).
- 2 Assembly all the components according to the illustration.
- 3 Turn the pressure spindle (K 22511) in by hand and secure that all parts are in place before adding pressure to the cylinder.

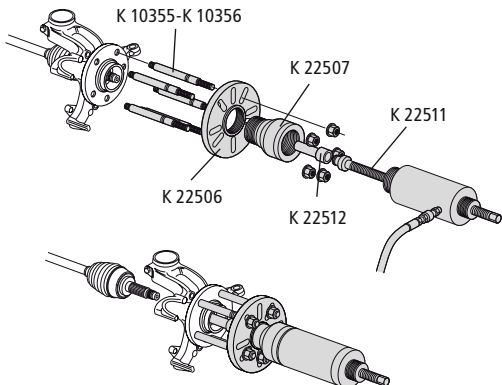

REMOVAL OF WHEEL HUB

- 1 Based on wheel nut dimension, select extension rods (K 10355-K 10356).
- 2 Assembly all the components according to the illustration.
- 3 Now the wheel hub can be hammered out.

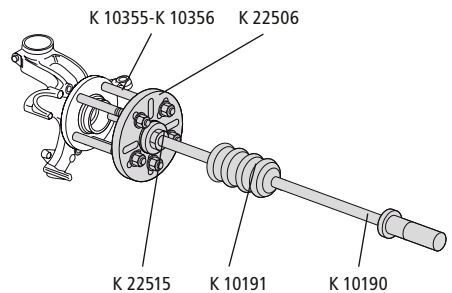



PARTS LIST

Stock No.	Description
K 22502	Manometer with adapter
K 22503	Hydraulic hose, 2,5 m
K 22504	Coupling and adapter for hose on cylinder
KR 22501 1	Gasket for foot pump lid

K 22500, K 22501

www.kamasatools.com