



Engine support,
universal

K 11300



INTRODUCTION

This engine support is designed to eliminate the need for floor based lifting equipment as support when engine and/ or gearbox needs to be dislocated temporarily for example at timing belt replacement or clutch repair. Work is facilitated by better accessibility and freedom to raise or lower the vehicle on the lift.

SAFETY AND PRECAUTION

- When working under the vehicle use all appropriate personal protection equipment including boots, gloves, safety glasses and safety hat.
- When adjusting the support frame take care to avoid trapped fingers.
- Ensure that there are no persons or obstructions underneath the vehicle when operating the engine support.
- When lowering the vehicle to work from above, take care not to lower the engine support onto the ground.
- Take care not to hang the engine support on fuel/brake lines, coolant hoses or wiring looms.
- Ensure that the mounting support hooks (F) are securely located on the crossmember and are not at risk of slipping or moving.
- Position the thrust pin pads (B) on strong, supported areas of the floor-pan, bulkhead or transmission tunnel (not for example, in the middle of the floor).

PRODUCT DESCRIPTION

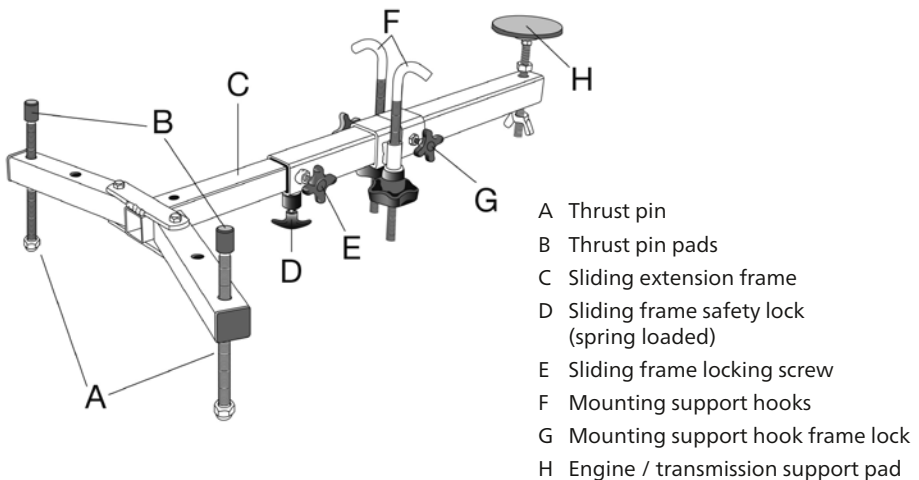

USE AND OPERATION

Note. Refer to the manufacturer's instructions in order to correctly removing components. The following notes and diagrams are provided as a guide only. No liability is accepted for incorrect use of this product.

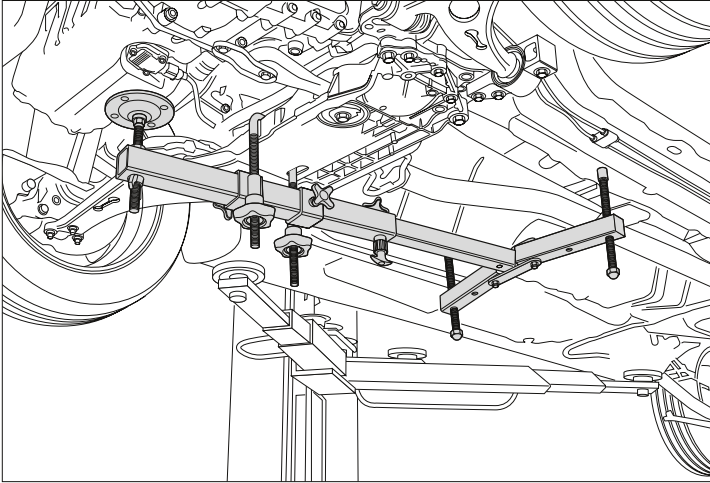

- Set the initial support frame adjustment on the floor under the vehicle before lifting it into position. Set support pad **(H)** low to assist fitting.
- To enable the frame length to be extended, release the spring loaded safety lock **(D)**. When correct length is reached, lock frame with the locking screw **(E)**.
- The mounting support hooks **(F)** are hooked over the main engine/ transmission support crossmember, or through convenient access holes.
- Slide the hooks **(F)** along the frame into position, secure by tightening the locking screws **(G)**. Hooks can then be adjusted to attach to crossmember, and secured in the correct position.
- Thrust pins **(A)** can be mounted in two positions in the adjustable arms, offering maximum flexibility. The weight of the engine or transmission is now transferred across the frame to the thrust pins. Position the thrust pins by choosing strong, supported areas of the floor, bulkhead or transmission tunnel, to bear this weight.
- Adjust the engine/transmission support pad **(H)** up onto a suitable area on the engine or transmission that is being supported.
- The pad **(H)** is easily adjusted once work is underway.



K 11300

www.kamasatools.com